

7820

Integrated Radio Transmitter

Installation and Set-Up Guide

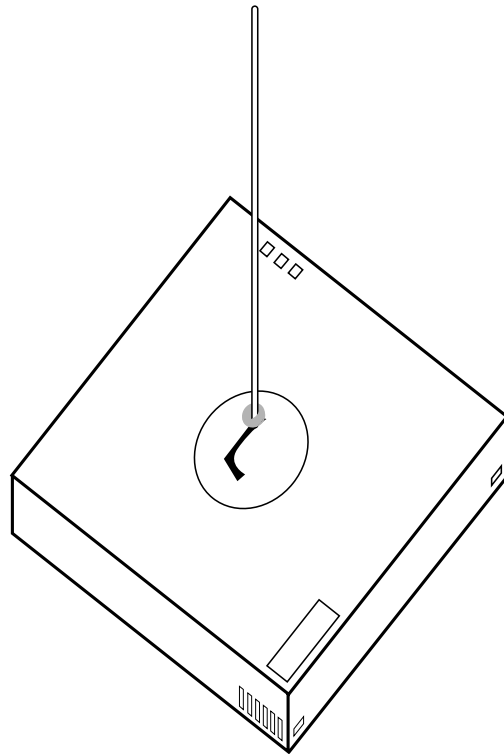

TABLE OF CONTENTS

SECTION 1: GENERAL DESCRIPTION	7
Selection of Inputs	7
Programmable Features	7
Antenna Included	7
Self-Diagnosing Transmitter	8
Power Supply	8
Emergency Battery	8
Optional Adapter	8
SECTION 2: SYSTEM OPERATION	9
Operation of the 7820 Radio	9
Zone (Channel) Options	10
Radio Supervision	10
Input Power	10
Emergency Battery Operation	11
LED Indications	12
Radio Fault Red LED Flash Patterns	12
SECTION 3: INSTALLATION AND POWER-UP PROCEDURE	13
Setting the Alarm Trigger Option	13
Wiring to the 7820 Radio	14
Power Connections	15
Wiring for Zone (Channel) Operation	16
Wiring for Radio Faults	17
“Fail-Safe” Relay Operation	19
Wiring for ECP Communication	19
Mounting	20
Powering Up	20
SECTION 4: PROGRAMMING THE 7820	21
Using a 7720P Programming Tool	21
7720P Normal & Shift Key (shift LED lit) Functions	21
Choosing Mode: ECP or Zone	21
ECP Unique Programming	22
Private System Users	23
Zone Mode Unique Programming	23
Password Protection	25
Subscriber Information	25
Private System Users	26
Pulse/Delay Zone Selection	26
Inverted Zone Selection	27
Restoral Reporting Zone Selection	28
Open/Close, Telco and Tamper Zone Selection	29
Redundant Central Station Reporting	29
Exiting Program Mode, Setting Defaults and Assigning Passwords	30
Setting Factory Defaults	31



SECTION 5: ANTENNA MOUNTING.....	32
Equipment Available.....	32
Selecting Site (FAST Mode).....	32
Outdoor Antenna Mounting	34
Indoor Antenna Mounting.....	36
Wall Mounting Using the 7825DP.....	37
SECTION 6: TESTING THE 7820.....	39
Radio Transmission Test.....	39
System Test.....	39
Status “S” Command.....	40
Battery Status “B” Command.....	40
ECP Status Codes	40
SECTION 7: TROUBLESHOOTING	42
CONNECTION DIAGRAMS	43
SECTION 8: SPECIAL NOTES FOR UL INSTALLATIONS.....	44
SPECIFICATIONS	45
SECTION 9: APPENDICES	46
Unique Contact ID Messages Generated in ECP Mode	46
ADEMCO High Speed Format	46
CONTACTING TECHNICAL SUPPORT	47
INDEX.....	48
FEDERAL COMMUNICATIONS COMMISSION (FCC) STATEMENT	49
TO THE INSTALLER.....	49
THE LIMITATIONS OF THIS RADIO COMMUNICATIONS SYSTEM	49
ADEMCO LIMITED WARRANTY	51

LIST OF FIGURES

Figure 1:	7820 Radio showing Trigger Select Jumpers.....	13
Figure 2:	Wiring the 7820 Zone 1 Input to trigger on (+) Bell Output voltage	16
Figure 3:	Wiring the 7820 Zone Inputs to voltage triggers, which generates (+) voltage	16
Figure 4:	Wiring the 7820 Zone 1 Input to be triggered by an ADEMCO 4204 output relay.....	17
Figure 5:	Wiring the 7820 I/O Connector to send a fault to the alarm panel	17
Figure 6:	Wiring the 7820 RY option board to trip a zone on an alarm control when a radio fault occurs (N/C config.).....	18
Figure 7:	Wiring the 7820RY option board to trip a zone on an alarm control when a radio fault occurs (N/O config.).....	18
Figure 8:	Wiring the 7820 for ECP data communication	19
Figure 9:	Ceiling and wall mount of antennas.....	34
Figure 10a:	Various parts of the 7825	35
Figure 10b:	Mounting the bracket to a pole/pipe	35
Figure 10c:	Optional No. 7825MB Floor Mount Bracket.....	35
Figure 10d:	N Connector Cable assembly.....	36
Figure 11a:	Standard wire antenna mounting.....	36
Figure 11b:	Wall mounting using the 7825DP	37
Figure 12:	Mounting with the 7625-3dB Gain and the 7720ANT Adapter	37
Figure 13:	I/O wiring harness.....	43
Figure 14:	7820RY Option board connections.....	43

CONVENTIONS USED IN THIS MANUAL

Before you begin using this manual, it is important that you understand the meaning of the following symbols (icons).

UL	These notes include specific information which must be followed if you are installing this system for a UL Listed application.
 CRITICAL NOTE	This symbol indicates a critical note that could seriously affect the operation of the system, or could cause damage to the system. Please read each warning carefully. This symbol also denotes warnings about physical harm to the user.
 IMPORTANT	These notes include information that you should be aware of before continuing with the installation, and which, if not observed, could result in operational difficulties.

Section 1: GENERAL DESCRIPTION

The 7820 is the subscriber end of a Long Range Radio Alarm reporting system. It is comparable to a digital communicator, but instead of transmitting signals over telephone lines, it transmits radio signals to the central monitoring station. This allows faster and more secure reporting.

The 7820 is compatible with existing installations using ADEMCO equipment or other control panels. The 7820 can be used in conjunction with digital communicators on the same system, each acting as backup to the other.

The entire radio link equipment, including alarm panel interface, transmitter and antenna, is housed in a single unit, requiring only 12 volt DC power and alarm inputs from an alarm panel.

UL

This radio is not UL Listed for Fire Alarm Service. Fire reporting is a supplemental use of this product.

Features of the 7820 radio include:

Selection of Inputs

- Provides 4 zone (channel) inputs that can be triggered either by a voltage or by removal of voltage.
- Provides ECP communication (connected through the keypad terminals) to certain ADEMCO control panels.



IMPORTANT

1. **Either zone (channel) inputs or ECP communication may be used, but not both.**
2. **ECP features are compatible *only* with 685 software revision 4.7 and higher, and 685-5 software revision 8.1 and higher.**

Programmable Features

Programming options include zone (channel) designations for the following:

- Inverted trigger inputs
- Telco fault input
- Delayed reporting (1-127 seconds)
- Open/Close reporting
- Steady or pulsing on input

Options are programmed through the use of a 7720P Programming Tool.

Antenna Included

The 7820 comes with an omni-directional wire antenna. If desired, an optional antenna may be used instead (see Section 5: ANTENNA MOUNTING for a list of compatible equipment).

Self-Diagnosing Transmitter

The following malfunctions are reported to the control panel either by tripping a zone on the control panel using the fault output on the radio, or by communication through the ECP (keypad) bus:

- Antenna fault
- Low internal DC voltage
- Internal RF circuit problems

A fault condition can be transmitted to the central station from the control panel if the radio's fault output is connected to a protection zone, and that zone is programmed to send a report.

Power Supply

The 7820 is powered from the alarm control's 12V auxiliary output, or from a battery-backed 12V auxiliary power supply. If AC to the power supply is lost, the radio will operate on the power supply's backup battery. Section 2 provides installation details which will ensure the adequacy of the panel power supply.

Emergency Battery

If input power to the 7820 is completely lost, an optional emergency battery may be installed in the radio to transmit one last message to the master station network before shutting down.

UL	An emergency battery (a single 9-volt alkaline) is required for UL installations.
-----------	--

Optional Adapter

The ADEMCO 7820RY Adapter provides a relay output status over the radio to the control panel, as well as a hardwired connection to the control panel.

Section 2: SYSTEM OPERATION

This section provides the following information:

- Operation of the 7820 Radio
- Zone (channel) options
- Radio supervision
- Input power
- Emergency battery operation
- LED indications

Operation of the 7820 Radio

The 7820 receives alarm and restore signals from the alarm control panel and converts these signals to radio messages, which are transmitted to the master station network, which, in turn, relays the messages to the central station. The 7820 has 4 zones (channels) that can be triggered by one of the following inputs:

- Voltage (4.5 - 14.2VDC)
- Removal of voltage (0VDC)
- Application of a ground (zones 1 and 2 only)*

* Application of a ground applies if zones (channels) 1 and 2 are set to activate on GND (by the Trigger Select jumper) and configured to "invert" their inputs.

If using voltage to trigger one or more of the radio's zone (channel) inputs, the voltage may be applied from one of the following sources, **for example**:

- Bell output of an alarm control panel
- Voltage trigger outputs of an alarm control panel
- Output relay, which can be set up to either apply or remove voltage from the radio's input

UL

Voltage triggers from the control panel must be suitable for use in Certificated Installations.

If using removal of voltage to trigger one or more of the radio's zone (channel) inputs, the "normal" voltage would be applied from one of the following sources:

- External source, through an output relay, which, when activated, would simply remove voltage from the radio's input
- Internal source (applies to zones 1 and 2 if Trigger Select Jumper set to activate on GND, which would require a dry contact closure to ground through a relay in order to activate)

Alternatively, the radio's ECP inputs can be connected to the alarm control panel's keypad terminals and can receive data communication directly from the alarm control.

At this time the following panels support this option:

<u>ADEMCO</u>	<u>First Alert</u>
Vista-10	FA 140
Vista-10SE	FA 142C
Via-30P	FA 160C
Via-30PSE	FA 162C
Vista-20	
Vista-20SE	



Either the zone (channel) inputs or ECP data communication may be used, but not both.

Zone (Channel) Options

Zones (channels) 1 and 2 are jumper-selectable for either a (+V) or (GND) trigger. Zones (channels) 3 and 4 are set up strictly for a (+V) trigger. If this is not desired, each channel may be programmed to "invert" its input, which means that it will be triggered when the *opposite* condition occurs. Other channel options include:

- Telco fault input (triggered when the phone line to the control panel loses voltage)
- Delayed reporting (gives user a chance to cancel the alarm, which helps to reduce false alarms)
- Open/close reporting (triggered when the user arms and disarms alarm control panel)
- Steady or pulsing on input

Radio Supervision

The 7820 periodically transmits supervisory and status messages to alert the network that it has communication integrity. If no messages are received during the supervisory window, the network will generate a communication failure signal to the central station.

Additionally, the radio has a fault output that can be connected to a zone on an alarm control panel to trip that zone if a radio fault does occur. This output would be used if using the Zone (channel) mode on the radio. If using ECP mode, the radio can communicate directly with the panel.

In Zone (Channel) mode only, the 7820 provides status information via its serial port using either a 7720P Programming Tool or a computer terminal. This allows radio status to be displayed on command (see Section 6: TESTING THE 7820 for more information regarding the "S" command and status messages).

Input Power

The 7820 Radio is powered by a 12VDC connection from the alarm control panel. The current draw is approximately 100mA at normal room temperature, and increases to 225mA when the ambient temperature is below 5°C (41°F). This must be taken into consideration when determining the total current draw from the control panel. If there is not enough current available from the panel, a 12VDC auxiliary power supply may be used. The power supply must have its own backup battery, as this is the primary battery backup for the radio in the event of AC failure (to the control panel or auxiliary power supply). The following power supplies have been tested and are known to work properly with the 7820: ADEMCO model AD12612 and Altronix models AL612 6-12VDC and AL100UL. These supplies must be used with 12 volt 1.2 amp-hour backup batteries.



The current drains noted above are for the 7820 Radio only. When a 7720P Programming Tool is plugged into the 7820, it draws an additional 100 mA of current.

Emergency Battery Operation

In the event of a total loss of input power, an optional emergency battery may be installed in the 7820. This is necessary in order for the radio to transmit the loss of power condition, which may be due to tampering with the connection between the control panel and the radio. The only emergency battery you may use is one 9-volt alkaline battery (battery life expectancy is up to five years).

The radio tests the condition of its emergency battery every 24 hours. If the radio's emergency battery drops below 7.4 volts (+/- 5%), the radio will transmit a low battery message to the central station, and a low battery restore message when the battery voltage returns to normal. If ECP communication is being used, the radio communicates the message to the control panel as well.

If there is insufficient input voltage to the radio (less than 10.2VDC), the radio's emergency battery will allow the radio to send a power lost message group (AC Fail) and then shut down until sufficient operating voltage is restored.

If the input voltage drops below 10.2VDC and the radio's emergency battery drops below 7.4 volts, the 7820 will not be able to transmit at all. In this case, the radio will be completely shut down until the external input voltage returns to a minimum of 11.5VDC.

 IMPORTANT	<ol style="list-style-type: none">1. If the radio is programmed to use an emergency battery but one is not connected, a low battery message sequence will be transmitted during the first battery test period. This will not affect the operation of the radio, as long as external DC power is available.2. A battery restore message will be sent at the next battery test interval time after the battery has been replaced (this could take up to 24 hours). Alternatively, if a 7720 Programming Tool is in use, a battery test can be forced by the SHIFT-B command. This will cause the restore message to be sent immediately.
---	---

LED Indications

LED	State	Meaning
Green	Flash	With yellow solid = message transmission. With yellow flashing = HS antenna test.
Yellow	Solid Rapid Flash (10 per second) Slow Flash (1 per second)	Transmission cycle ON. Test or FAST message. Normal operation.
Red	Solid Pattern	Radio fault detected. See Flash Patterns table.
Yellow and Red	Flashing in unison	Loss of communication between radio and alarm panel (ECP mode only).
All illuminated	Consecutive Slow unison	Power on/reset sequence. Repeated twice before entering normal mode. Press ENTER during cycle to enter program mode. Radio is not properly programmed. Will continue until ENTER is pressed to enter programming mode.

Radio Fault Red LED Flash Patterns

#	Flash	Reason
1	S-L-L-L	Internal radio fault
5	S-L-L-S	Low power or bad VSWR
CRC	S-S-L-S	RAM/EEPROM corruptions
<p>S = Short flash (150mS); L = Long flash (600mS) # = Fault code number, as reported by a 7720P Programming Tool. See Status "S" Command in Section 6: TESTING THE 7820 for additional status information.</p>		

Section 3: INSTALLATION AND POWER-UP PROCEDURE

This section provides the following information:

- Setting the Alarm Trigger option
- Wiring to the 7820 Radio
- Power connections
- Wiring for zone (channel) operation
- Wiring for radio faults
- Wiring for ECP communication
- Mounting the 7820 Radio
- Power-up procedure

Setting the Alarm Trigger Option (applies to Zone mode only)

The Alarm Trigger option allows you to determine whether zones (channels) 1 and 2 will be activated by either a ground or by a positive voltage.

To set the Alarm Trigger option, first remove the cover of the 7820 by inserting a screwdriver into the four removal points at the bottom of the unit and gently releasing the locking tab from the cover slots.

Next, set the Trigger Select Jumper for zones 1 and 2 to activate on either a ground or with a positive voltage, whichever you require (see Figure 1 below).

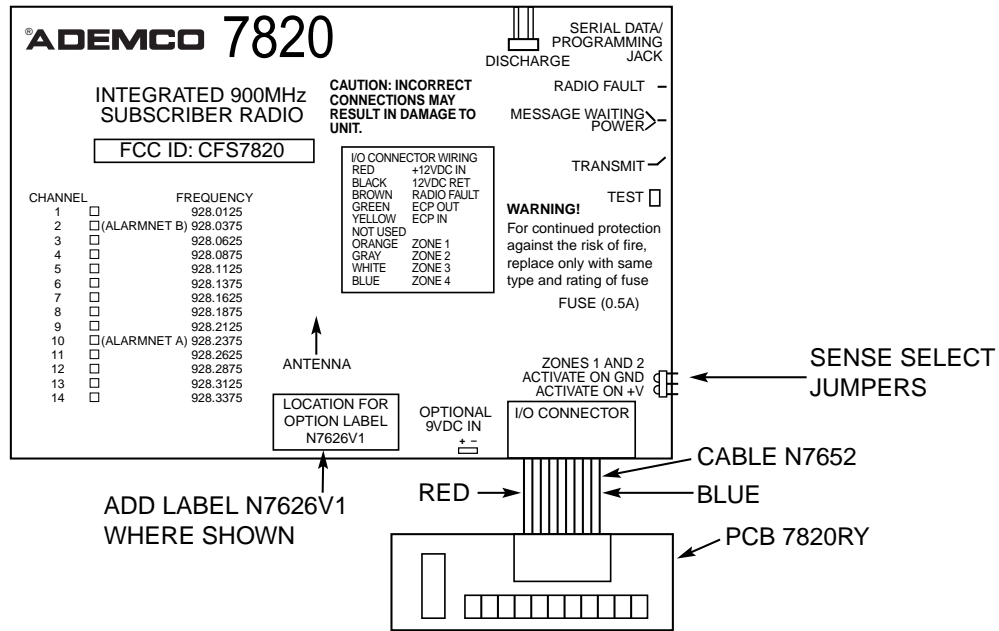

Figure 1: 7820 Radio showing Trigger Select Jumper

If the jumper is connected to ACTIVATE ON +V, then +4.5 to +14.2 volts must be applied to zones 1 and 2 to trigger an alarm. (Zone 1 and zone 2 connections to the radio will be at ground potential unless externally pulled up.)

To reverse the *electrical* sense of zones 1 and 2, connect the jumper to **ACTIVATE ON GND**. (Zone 1 and zone 2 connections to the radio will be at a positive potential unless externally pulled to ground.) The *triggering* sense of either above condition can be inverted in programming. See Questions 12 and 13 in Section 4: PROGRAMMING THE 7820.

Wiring to the 7820 Radio

If the 7820 is to be powered from the alarm control panel, run all wires (power and alarm) from the control panel to the 7820 Radio location. If using Zone (Channel) mode, run a wire for each input zone, as well as two wires for power. If using the radio fault output, run two additional wires for connecting to a zone on the alarm control panel. In ECP mode, only four wires are required (two for power, two for data). Observe the wire length/gauge limitations for DC power, input zone, and ECP connections outlined in the paragraphs to follow.

The alarm and power wires can be brought into the transmitter through the base or through the cover. If they are to be brought through the cover, cut out the optional wire entry port.

<u>I/O CONNECTOR WIRING</u>	
RED	+12VDC IN
BLACK	12VDC RET
BROWN	RADIO FAULT
GREEN	ECP OUT
YELLOW	ECP IN
(NOT USED)	
ORANGE	ZONE 1
GRAY	ZONE 2
WHITE	ZONE 3
BLUE	ZONE 4

If using the I/O Connector, the colored wire designations are indicated above.

7820RY TB1 WIRING CONNECTION DIAGRAM (OPTION BOARD)										
+12VDC	12VDC RET	ECP OUT	ECP IN	ZONE 1	ZONE 2	ZONE 3	ZONE 4	RADIO FAULT		
								N.C.	COM	N.O.
1	2	3	4	5	6	7	8	9	10	11

If using the 7820RY Option Board, the terminal designations are indicated above.

Power Connections

The 7820 requires an input voltage of 12-15VDC that can supply 125mA continuous current and as much as 225mA during low-temperature operation. This power can be obtained from the alarm control panel's auxiliary output, or, if there is not sufficient current available, from a battery-backed auxiliary power supply. For non-UL installations, ADEMCO recommends the Altronix model AL612 6-12VDC power supply or the ADEMCO Model AD12612 with a gel-type sealed lead acid battery (12V, 1.2AH). For UL installations, the alarm control panel's auxiliary output may be used, provided that sufficient current capability has been determined. Otherwise, use Altronix model AL100UL, and follow the unit's enclosed instructions regarding transformer and battery requirements.

 CRITICAL NOTE	If using the alarm control panel to power the 7820, be sure that the maximum current draw of all devices connected to the control panel (including the 7820) does not exceed the control panel's rated auxiliary power output. Overloading the control panel will result in a malfunction of both the transmitter and the alarm control panel.
---	---

If using the alarm control panel to supply power, do the following:

1. Connect the black wire from the I/O Connector (or terminal 2 on the 7820RY Option Board) to the Ground terminal of the panel.
2. Connect the red wire from the I/O Connector (or terminal 1 on the 7820RY Option Board) to the +12VDC terminal of the panel.

If using an auxiliary power supply, do the following:

1. Connect the black wire from the I/O Connector (or terminal 2 on the 7820RY Option Board) to the negative terminal of the power supply.
2. Connect a black wire from the negative terminal of the power supply to the Ground terminal of the alarm control panel.
3. Connect the red wire from the I/O Connector (or terminal 1 on the 7820RY Option Board) to the +12VDC terminal of the power supply.

 IMPORTANT	The negative side of the power supply must be connected to the same electrical point as the Ground terminal of the alarm control panel. Use color-coded wires for the power connections. It is recommended that the positive connection be red and the negative connection be black.
---	---

Maximum DC Power Wire Run Lengths

Gauge	Distance (ft)
18	300
20	200
22	125

Wiring for Zone (Channel) Operation

If using Zone (Channel) mode, connect a wire from the triggering source (bell output, voltage trigger, etc.) to each zone on the radio to be used. Examples of zone (channel) connections are shown in Figures 2 and 3.

ALARM CONTROL

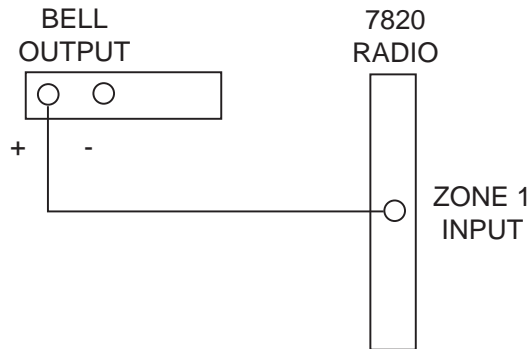

Figure 2: Wiring the 7820 Zone 1 Input to trigger on (+) Bell Output voltage

ALARM CONTROL

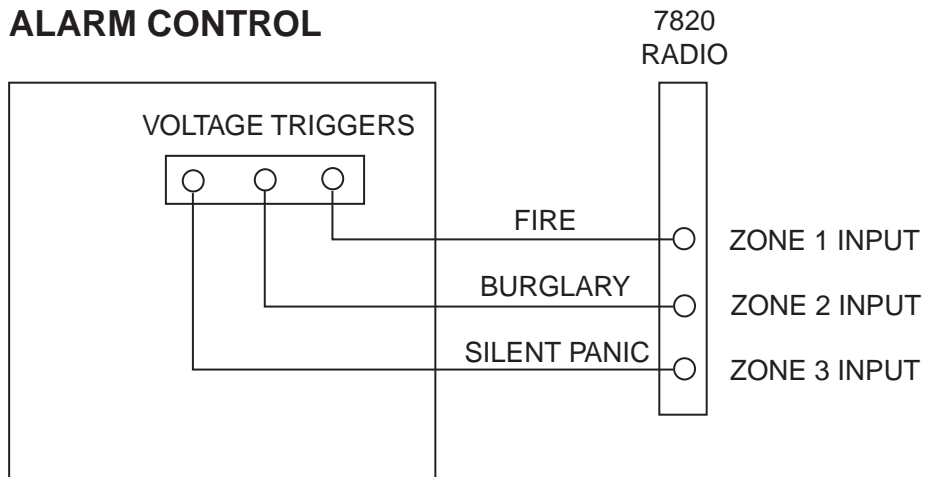

Figure 3: Wiring the 7820 Zone Inputs to voltage triggers, which generate (+) voltage on each wire for different alarm conditions.



IMPORTANT

For input zone (channel) connections, 22 gauge or larger wire must be used, regardless of distance.

If the alarm control panel is activating an output relay that will be used to apply voltage to one of the input zones on the radio, do the following:

1. Connect the arm (common) of the relay to 12VDC.
2. Connect the N.O. contact of the relay to the input zone. When the relay is activated, voltage will be applied to the zone, causing the radio to send its message (see Figure 4 below).

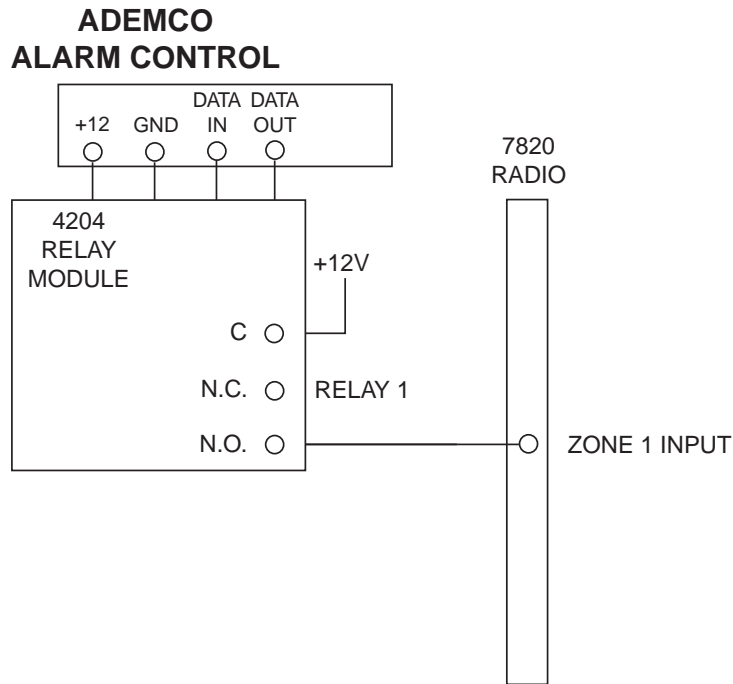

Figure 4: Wiring the 7820 Zone 1 Input to be triggered by an ADEMCO 4204 Output Relay.

Wiring for Radio Faults

When Zone mode operation is enabled, an extra output is available to send a radio fault to the alarm control panel. If using the I/O Connector, the fault signal is sent through the brown wire, and is an open-collector output. It can be programmed normally low or normally high, although normally low is recommended (answer Y to program question 25 "FLT OUT ON (Y/N).") Thus, if a line should break or be cut, a radio fault will be sensed at the panel. Wiring to the alarm control panel requires an end-of-line resistor on the high side of the protection zone (see Figure 5 below).

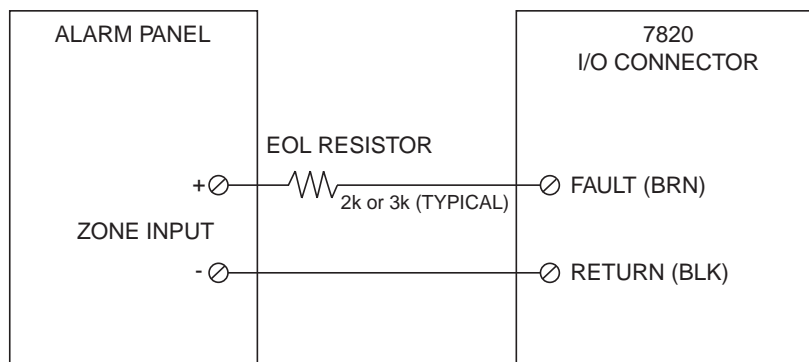

Figure 5: Wiring the 7820 I/O Connector to send a fault to the alarm panel.

If using the 7820RY Option Board, a relay output is provided for wiring to the control panel (N.O. or N.C. connections may be used). If normally closed contacts are used, a resistor is needed between the N.C. contact (terminal 9 of the 7820RY) and the high side of the protection zone. If normally open contacts are used, a resistor must be connected across the N.O. and Common terminals (terminals 10 and 11 of the 7820RY Option Board). Figures 6 and 7 show fault relay connections to the alarm control panel.

ALARM CONTROL

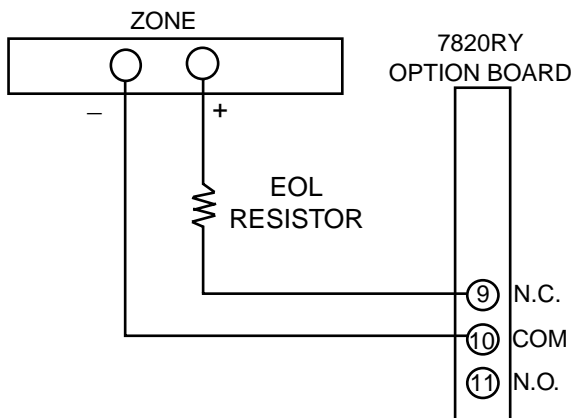

Figure 6: Wiring the 7820RY Option Board to trip a zone on an alarm control when a radio fault occurs (N/C) configuration).

ALARM CONTROL

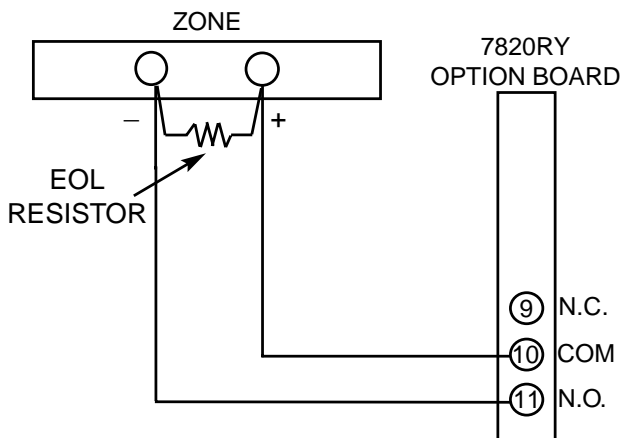

Figure 7: Wiring the 7820RY Option Board to trip a zone on an alarm control when a radio fault occurs (N/O configuration).

 IMPORTANT	<p>See the control panel instructions for the resistor value required for zone supervision.</p>
---	---

"Fail-Safe" Relay Operation

Normally, the relay will be energized when there is a radio fault. In order for the relay to be energized, the radio must have power. To have the relay change state when the radio loses power completely, it is possible to program the relay so that it is normally "energized" (i.e., the normally open contacts close and the normally closed contacts open) so that in the event of a complete loss of power, the relay will return to its de-energized state, causing the fault to be sent.

If programming the relay for "Fail-Safe" operation, wiring to a normally closed protection zone on the alarm control panel requires wiring to the Common and N.O. contacts of the relay, because these contacts "close" when the relay is energized (which would be under normal circumstances). To program the relay for "Fail-Safe," answer Y to program Question 25 "FLT OUT ON (Y/N)."

Wiring for ECP Communication

Only certain panels support ECP data communication at this time. They are the ADEMCO VISTA-10, VISTA-20, and Via-30P. ECP data connections are the Data In and Data Out terminals that the keypads and other peripheral devices (RF receiver, VIP module, etc.) use for communication with the panel. To wire the radio for ECP communication, do the following:

1. Connect the green wire of the I/O Connector (or terminal 3 on the 7820RY option board) to the "Data In" terminal of the alarm control panel.
2. Connect the yellow wire of the I/O Connector (or terminal 4 on the 7820RY option board) to the "Data Out" terminal of the alarm control panel.

ALARM CONTROL

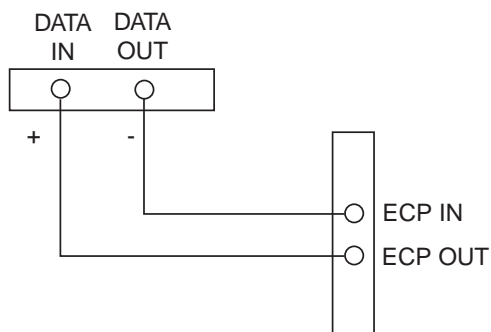

Figure 8: Wiring the 7820 for ECP data communication

Wire length/gauge limitations are the same for the control panel keypads as they are for the radio. Check with the control panel Installation Instructions.

Mounting

Determine the best location for strong radio communication with the Master Station network using the 7915 or 7715 FAST Tool. Mount the 7820 to a horizontal or vertical surface, depending on the antenna used. Be sure to allow access to the programming port when mounting.

The 7820 is intended to be mounted to a horizontal surface, preferably on a ceiling, or in an attic location on top of a joist when using the supplied wire antenna.

If using the optional 7820DP Antenna, the 7720ANT Antenna Kit, or the 7825 Antenna, the 7820 Transmitter can be mounted to a vertical surface such as a wall or beam.



IMPORTANT

Do not mount the 7820 on a vertical metal surface if the antenna is to be mounted directly on the radio.

Section 4: PROGRAMMING THE 7820

Using a 7720P Programming Tool

The 7720P Programming Tool is powered by the 7820, and connects to the SERIAL DATA PROGRAMMING JACK on the 7820 PC Board by means of the modular cable supplied with the 7720P.

Each key of the 7720P has two possible functions: a normal function and a SHIFT function. To perform a normal key function, simply press the desired key. To perform a SHIFT key function, press SHIFT key, then press desired function key.

7720P Normal & Shift Key (shift LED lit) Functions

Key	Normal Key Function	SHIFT Key Function
BS/ESC	[BS]: Press to delete entry Also, can reset EEPROM defaults *	[ESC]: Press to quit program mode
↓/↑	[↓]: Scroll down programming	[↑]: Scroll up programming
N/Y	[N]: Press for "NO" answer	[Y]: Press SHIFT-Y for "YES" answer
SHIFT	Press before pressing a SHIFT key function. Will light SHIFT LED. LED goes out once a key is pressed. Press again for each SHIFT function desired.	
1/A	[1]: For entering the number 1	[A]: Used for entering C.S. ID number
2/B	[2]: For entering the number 2	[B]: Used for entering C.S. ID number
3/C	[3]: For entering the number 3	[C]: Used for entering C.S. ID number
4/D	[4]: For entering the number 4	[D]: Used for entering C.S. ID number
5/E	[5]: For entering the number 5	[E]: Used for entering C.S. ID number
6/F	[6]: For entering the number 6	[F]: Used for C.S. ID & FAST mode
7/S	[7]: For entering the number 7	[S]: Press to display diagnostic status
8/T	[8]: For entering the number 8	[T]: Press to send TEST messages
9/X	[9]: For entering the number 9	[X]: Press to reset the 7820
/SPACE	[]: Not used with 7820	[SPACE]: Not used with 7820
0	[0]: For entering the number 0	No SHIFT function
#/ENTER	[#/ENTER]: Press to accept entries	No SHIFT function

* Active only when the "REVIEW?" prompt is displayed.

Choosing Mode: ECP or Zone

Connect the 7720 P tool and apply power to the radio by disconnecting the I/O connector from the radio. Connect power to the red and black leads. Reconnect the I/O connector.

The transmitter LEDs will *rapidly* flash in the following pattern; five red flashes, five yellow flashes, five green flashes. Press **ENTER** during this time. This will allow the radio to be configured (or reconfigured) to operate in the Zone mode or the ECP mode regardless of prior configuration. The following question will appear:

ECP Radio [Y/N]

Answer Y or N, as desired, and press ENTER. The LEDs will now flash in the sequence red/yellow/green, red/yellow/green. Press ENTER during the time the LEDs are flashing. The PITTWAY banner will appear and you will be in the chosen mode. For ECP mode see page 22, for Zone mode see page 24.



IMPORTANT

Timing is important. If you do not press ENTER in a timely manner, the unit will not respond as described. To start over, disconnect the power from the radio by disconnecting the I/O connector. Discharge the radio by shorting the pins at the top of the radio labeled DISCHARGE for five (5) seconds, then follow the power up procedure above.

The radio will wait 10 seconds for a response. Enter Y to configure the radio for ECP mode, or N to configure the radio to Zone mode. If the radio receives no response or something other than a Y or N, the radio will use the configuration stored in its EEPROM. The default configuration is Zone mode. **If the configuration is changed, the EEPROM must be reprogrammed.**

If the new configuration is ECP mode, and the panel is not capable of programming the radio, then the 7720P tool may be used during the power-up sequence. (See ECP Unique Programming, below.) If the new configuration is Zone mode, the 7820 sign-on will appear immediately.



IMPORTANT

When the radio has been set up in ECP mode, the 7720P may only be used during the power-up mode to configure and program the radio. Once the radio is active in ECP mode, the 7720P is not recognized.

If the 7820 has already been programmed for a given configuration, the LEDs will begin to flash according to their function. If the 7820 has not been programmed, regardless of configuration, the LEDs will flash in unison indefinitely.

ECP Unique Programming

When the ECP mode has been selected, the following message will appear on the 7720P display for one second:

7820ECP XXX
© Pittway 1995

(XXX indicates current software revision)

The first programming question will appear after the above sign-on message. *All* displayed questions must be answered. The subsequent question will not be displayed until the current question is answered. Unlike the procedure in Zone mode, pressing ESC in ECP mode will *not* bring the list of programming questions to the end if any question has been left unanswered.

1. Enter the Device Address of the radio. For VIA 30+, VISTA 10 and VISTA 20, **this must be 3**. For other control panels, see the control panel's Installation Instructions.
2. Enter the 4-digit customer account number, 0001-9999. This ID number will appear in the messages generated by the radio. Messages generated by the panel and transmitted by the radio will contain the ID number programmed into the panel. The radio and the panel should have the same ID number, if possible.



IMPORTANT

If a different 4-digit customer account number is used in the radio than is programmed into the alarm control, the radio will transmit radio-specific messages (power-on reset, AC fail, etc.) using the radio customer number, and alarm messages using the control panel's customer number. If these numbers are different, you will be billed for two AlarmNet radio accounts.

3. Enter Y for odd system flag; N for even system flag.
4. Status reporting is always enabled. Enter the desired interval as follows:
 Y = Every 15 minutes (6-hour window for COM-FAIL report-**High Security**)
 N = Short form: Every hour (standard 24-hour reporting for COM-FAIL-**Basic Service**).
Must be Y for UL installations.
5. Enter Y if an AlarmNet installation. Enter N for Private System users (skip to Question 7).
6. Enter the primary central station's system ID number, 1-7F (will not be displayed for Private System users).

Private System Users (AlarmNet users skip to #9)

7. Enter the Private System routing code, 0-7 (will not be displayed for AlarmNet users).
8. Enter the Private System channel number, 1-F (will not be displayed for AlarmNet users).
9. Enter Y for 135-second interval antenna test. Press N if no antenna test is desired. **Must be Y for UL installations.**
10. Enter Y if optional will be used. **Must be Y for UL installations (a battery must be installed).**
11. If Y is selected, the Radio ID number will replace the panel Subscriber ID in panel-generated messages with the Radio ID number.
 If N is selected, the radio will send panel-generated messages with the panel Subscriber ID number.
12. **This must be programmed with a value, even if it is the same as the primary central station.** The alarm panel has the option to send a selected message to the second central station.
- Enter Y to review the programming options and to ensure that the correct responses have been made. Parameters can be changed during review. Enter N to end programming session.

Zone Mode Unique Programming

After connecting the 7720P Cable, power up the 7820 (apply power to the control panel). If the 7820 is already powered up and is presently programmed for Zone mode, press SHIFT-X on the 7720P Tool. Otherwise, power the radio off, then on again.

The following will be displayed:

```
7820 xxx
(c) Pittway 1994
```

xxx = current software revision level



IMPORTANT

If the above procedure does not display this screen, use the procedures described in Powering Up and Choosing Mode on Page 18 and enter [N]o to ECP selection.

Programming is accomplished by answering displayed questions. Most questions require only a **[Y]es** or **[N]o** response, while others require a numerical response (ID numbers, etc.). Press ENTER to accept each response and proceed to the next question. A "?" indicates an invalid entry. The current value is displayed on the second line in parenthesis (.). To accept the current entry, simply press the ENTER key. Use the UP/DOWN arrow keys to scroll through the programming questions without changing any values.

Pressing SHIFT-X will reset the 7820 to its initial power-up phase if it has already entered normal operating mode. The 7820 reads its EEPROM to determine its pre-programmed parameters. A CRC of the EEPROM locations is also read. If the computed CRC does not match the one read from EEPROM or if the programming parameters are invalid, the 7720P LCD displays "NO PROG." While the three LEDs flash in unison, press ENTER to begin programming.

If program mode is entered and the EEPROM contains invalid programming parameters or the CRC is incorrect, the 7820 displays:

```
EEP ERR/NO PROG
Clear Values?
```

Press Y. If N is selected, the 7820 displays:

```
CANNOT PROCEED
'TIL EEP ERASED!
```

When Y is selected, all parameters are reset, and you must be prepared to program the radio at this time.

Password Protection

By assigning passwords, the programming menu can, if desired, be split into two menus: a Central Station Menu (which contains all programming questions) and a Subscriber Menu (which contains a subset of the central station menu).

 IMPORTANT	If using a terminal to program passwords, use only those characters available on the 7720P (A, B, C, D, E, F, S, T, X). This allows later access using a 7720P Programming Tool.
---	---

Up to 2 passwords can be assigned, one for each of the menus. Once a password is assigned (for either menu), two menu selection prompts appear upon entering programming mode:

CHOOSE FROM THE
FOLLOWING
MENUS:

Central Sta (1)
Subscriber (2)

Enter 1 or 2 depending on which menu is to be accessed, then enter the appropriate password when prompted. Passwords may consist of up to four alphanumeric characters. The first programming question in that menu is then displayed. See the Setting Defaults, and Assigning Passwords paragraph later in this section for assigning and changing passwords.

Subscriber Information

1. Enter the 4-digit customer account number, 0001-9999.
2. Enter Y for odd flag (bit value 1), N for even system flag (bit value 0).
This option is in the Central Station Menu only.
- 3a. Status reporting is always enabled. Enter the desired interval as follows:
Y = Every 15 minutes (6-hour windows for COM-FAIL report—
High Security)
N = Every hour (standard 24-hour reporting for COM-FAIL—
Basic Service)
This option is in the Central Station Menu only.
- 3b. If this option is chosen, the other possible options of section 3 will be cleared. The radio will send status once every 7 days. This option permits the installer to limit the amount of radio traffic generated by the 7820. COM-FAIL reporting is not available in this mode.
- 3c. If this option is chosen, the other possible options of section 3 will be cleared. The radio will send status once every 30 days. This option permits the installer to limit the amount of radio traffic generated by the 7820. COM-FAIL reporting is not available in this mode.
4. Enter Y if this is an AlarmNet installation. Enter N for Private System users (skip to Question 6).
This option is in the Central Station Menu only.
5. Enter the primary central station's system ID number, 1-7F (will not be displayed for Private System users). If radio is being installed on AlarmNet network, skip to 8a.

This option is in the Central Station Menu only.

Private System Users (AlarmNet users skip to #8)

6. Enter the Private System routing code, 0-7 (will not be displayed for AlarmNet users).

7. Enter the Private System channel number, 1-F (will not be displayed for AlarmNet users).

This option is in the Central Station Menu only.

 IMPORTANT	For questions 2, 3, 4, 5, and 7, see Exiting Program Mode, Setting Defaults and Assigning Passwords (pg. 30) for Central Station/Subscriber Menu Option.
---	---

Pulse and Delay Zone Selections

By configuring a zone as a pulsed zone, it is possible to use the bell output of a panel or siren driver to activate the radio directly when its signal is a pulsed output for fire and a continuous output for burglary. To implement a fire/burg. detection at the radio, connect the output directly to two zones on the 7820. Program the fire zone as a pulsed zone and the burglary zone as a delayed zone (this is to prevent this zone from reporting an alarm when the pulsed signals are detected). The number of pulses and the length of delay will be dependent on the particular panel or siren driver being used, and is therefore a programmable feature.

 IMPORTANT	<ol style="list-style-type: none">1. If using the bell output to provide a steady signal for burglary and a pulsing signal for fire, it is recommended that you program a 3-second delay and a delay pulse count of 3 for the steady zone so that the radio can determine what type of signal it is.2. Zones programmed for pulse cannot be designated as open/close or telco zones; an invalid entry message will occur, because the pulse zone takes priority over open/close and telco programmed zones.
--	--

8a. Press Y if zone 1 is connected to a pulsed bell output. Question 8c will appear. If N is pressed, Question 8b appears. **Must be N for UL installations.**

8b. Enter the reporting delay from 1-127 seconds for zone 1. Enter 00 for no reporting delay. **Must be 00 for UL installations.**

8c. If Pulsed Zone is answered Y, the next prompt is Pulse Cnt? Input the number of pulses required to place the zone in alarm. Default is (03).

9a. Press Y if zone 2 is connected to a pulsed bell output. Question 9c will appear. If N is pressed, Question 9b appears. **Must be N for UL installations.**

9b. Enter the reporting delay from 1-127 seconds for zone. Enter 00 for no reporting delay. **Must be 00 for UL installations.**

9c. If Pulse Zone is answered Y, the next question will be Pulse Cnt? Input the number of pulses required to place the zone in alarm. Default is (03).

10a. Press Y if zone 3 is connected to a pulsed bell output. Question 10c will appear. If N is pressed, Question 10b appears. **Must be N for UL installations.**

10b. Enter the reporting delay from 1-127 second for zone 3. Enter 00 for no reporting delay. **Must be 00 for UL installations.**

10c. If Pulsed Zone is answered Y, the next question will be Pulse Cnt? Input the number of pulses required to place the zone in alarm. Default is (03).

11a. Press Y if zone 4 is connected to a pulsed bell output. Question 11c will appear. If N is pressed, Question 11b appears. **Must be N for UL installations.**

11b. Enter the reporting delay from 1-127 seconds for zone 4. Enter 00 for no reporting delay. **Must be 00 for UL installations.**

11c. If Pulsed Zone is answered Y, the next question will be Pulse Cnt? Input the number of pulses required to place the zone in alarm. Default is (03).

Inverted Zone Selection

Zones 1-4 and the test zone can be programmed for inverted input signals.

12. Press Y if zone 1 is to be triggered by removal of voltage. Press N for normal input signal.

13. Press Y if zone 2 is to be triggered by removal of voltage. Press N for normal input signal.

14. Press Y if zone 3 is to be triggered by removal of voltage. Press N for normal input signal.

15. Press Y if zone 4 is to be triggered by removal of voltage. Press N for normal input signal.

 IMPORTANT	If the Trigger Select Jumper for zones 1 & 2 is set to activate on GND, these two zones must be inverted and will have an internal voltage applied to them normally. The application of a ground (applied through a relay) will trigger the zone.
---	--

Restoral Reporting Zone Selection

Restoral reporting can be enabled, disabled, or delayed. The delay option delays restoral reporting for about 1.5 minutes after the actual restore condition, which helps ensure that alarm messages reach the central station before the restore message. Note that if restores are enabled for a delayed zone, the restore condition must exist for at least 2.5 seconds (this is intended to prevent swinger conditions).

If any of the four zones (channels) have been programmed for pulse operation and restorals have been enabled, then, following the Restoral question, the 7720P will display "REST ON CHG (Y/N)." This feature is used when connecting two zones to the bell output, and, of the four zones, one zone is programmed for a steady signal and at least one is programmed for a pulsing signal.

When "REST ON CHG" is programmed for Y, if one of the two zones connected to the bell output goes into alarm, the radio will transmit a restoral message when the bell output changes from a steady to a pulse or from a pulse to a steady.

16. Press Y to enable restoral reporting for zone 1. Press N to disable restoral reporting. Press D for delayed reporting. **Must be Y for UL installations.**
- 16a. Press Y if restore is to be sent when the type of signal changes, i.e., when pulsing state changes to a steady state level (high or low) or when a steady state changes to a pulsing state.
17. Press Y to enable restoral reporting for zone 2. Press N to disable restoral reporting. Press D for delayed reporting. **Must be Y for UL installations.**
- 17a. Press Y if restore is to be sent when the type of signal changes, i.e., when pulsing state changes to a steady state level (high or low) or when a steady state changes to a pulsing state.
18. Press Y to enable restoral reporting for zone 3. Press N to disable restoral reporting. Press D for delayed reporting. **Must be Y for UL installations.**
- 18a. Press Y if restore is to be sent when the type of signal changes, i.e., when pulsing state changes to a steady state level (high or low) or when a steady state changes to a pulsing state.
19. Press Y to enable restoral reporting for zone 4. Press N to disable restoral reporting. Press D for delayed reporting. **Must be Y for UL installations.**
- 19a. Press Y if restore is to be sent when the type of signal changes, i.e., when pulsing state changes to a steady state level (high or low) or when a steady state changes to a pulsing state.

Open/Close, Telco, and Tamper Zone Selection

20. Enter the open/close reporting zone number, 1-4. A 0 entry disables open/close reporting. If the zone selected was programmed to be a pulse zone (see Questions 8-11), this zone number selection is invalid and will be tagged as an error.
21. Enter the physical telco line fault zone, 1-4. A 0 entry disables telco detection. **If this zone is the same as the open/close zone, this selection will automatically be set to 0 and telco detection will be disabled.** If the zone selected was programmed to a pulse zone (see Questions 8-11), this zone number selection is invalid and will be tagged as an error. For UL applications, the telco channel **MUST NOT** be disabled by entering 0.
22. The tamper zone is a programmable soft zone (used for a cover tamper) that is designated by a zone number between 5 and 8. Enter the tamper zone, 5-8. A 0 entry disables tamper detection. If tamper is enabled, delayed restores will be automatically generated. A tamper zone, **not** a 0 must be entered for UL installations.
23. Enter Y for 135-second interval antenna test. Press N if no antenna test is desired. **Must be Y for UL installations.**
24. Enter Y if optional battery will be used. **Must be Y for UL installations (a battery must be installed).**
25. Press Y if Fail-Safe mode is desired. If the 7820RY Option Board is not used, this should be programmed Y. If the relay option board is used, in this mode, the fault relay is normally energized in the event of a radio fault. Note that Fail-Safe mode with the relay board draws slightly more standby current. **Must be Y for UL installations.**
26. Press Y if radio fault line is to be latched upon detection of transmission error. Press N if a momentary signal upon detection of transmission error is desired. **Must be Y for UL installations.**

Redundant Central Station Reporting

27. Press Y if redundant reporting to a second central station is desired. Press N if not desired (skip to end).
Questions 28 through 36 will not be displayed on the 7720P.
28. Press Y to enable reporting to second central station for zone 1. Enter N to disable reporting.
29. Press Y to enable reporting to second central station for zone 2. Enter N to disable reporting.

30. Press Y to enable reporting to second central station for zone 3.
Enter N to disable reporting.
31. Press Y to enable reporting to second central station for zone 4.
Enter N to disable reporting.
32. Press Y to enable test reporting to second central station.
Enter N to disable reporting.
33. Press Y to enable tamper reporting to second central station.
Enter N to disable reporting.
34. Press Y to enable reporting of system report to second central station.
Enter N to disable reporting.
35. Enter the 4-digit customer account number for the second central station, 0001-9999.
36. Enter the secondary central station's system ID number, 1-7F.
This ID number must be different from the one programmed in Question 6 (which is the primary CS ID).

Exiting Program Mode, Setting Defaults, and Assigning Passwords

When the last question is answered, all entries are validated by the system. If no errors are found, the following is displayed:

REVIEW?

To review the programming options (to ensure that the correct responses have been made), press Y. The programming questions will be displayed again, starting with Question 1. Use the UP/DOWN arrow keys to scroll through the program fields without changing any of the values. If a value requires change, simply type in the correct value and press ENTER. When the last field is displayed, the REVIEW? question again appears.

If errors are found during the validation routine (values are out of range or there is a conflict of parameters), the REVIEW? question is replaced by the following:

ERRORS FOUND
HIT ANY KEY

Upon pressing any key, the first invalid entry is displayed. Correct the entry, then press ENTER to display the next invalid entry. When the last invalid entry is corrected, the system again performs a validation routine. If no errors are found, the REVIEW? question is displayed.

To display all program entries (not only invalid entries), press the UP arrow key. The previous question appears. Use the DOWN arrow key to display subsequent programming entries.

Setting Factory Defaults

The programming options can be globally reset to their factory default values by pressing ESC at the REVIEW? prompt. A confirmation prompt will appear. Press Y to reset, or press N to return to the REVIEW? prompt. If Y is pressed, all programmed values will be reset to their original factory settings.

To exit program mode and assign passwords, press N in response to the REVIEW? question. If no password has been assigned, the following appears:

ENTER PASSWORD?
[Y/N]

Passwords can be used to split the programming questions into two menus. See the paragraph earlier in this section. If a password is desired, press Y. The following prompts appear. Press N if no passwords are desired.

CHOOSE FROM THE FOLLOWING MENUS:	Central Sta (1) Subscriber (2)
----------------------------------	-----------------------------------

Enter 1 or 2 depending on the menu to which a password is to be assigned. When prompted, enter the desired password (up to 4 digits). You will then be prompted to re-enter it (as confirmation).

 IMPORTANT	If using a terminal to program passwords, use only those characters available on the 7720P to allow later access using a 7720P (A, B, C, D, E, F, S, T, X).
---	--

If a password has already been assigned for the current programming menu, the ENTER PASSWORD? prompt is replaced by the following:

CHG PASSWORD?
[Y/N]:

Press Y or N, depending on whether you want to change the password for the **current** programming menu. If [Y]es, you will be prompted to enter the new password twice (as confirmation). To clear an existing password, answer Y to the CHG PASSWORD? prompt, but press only the ENTER key when prompted for the new password and its confirmation.

When the password question(s) have been answered, the system exits program mode and returns to normal mode. The Programming Tool can then be disconnected, or can be used to trigger test messages. Refer to Section 6: TESTING THE 7820.

Section 5: ANTENNA INSTALLATION

This section provides the following information:

- Equipment available
- Selecting a site
- Outdoor antenna mounting
- Indoor antenna mounting

Equipment Available

The following optional antennas can be used with the 7820:

<u>Antenna</u>	<u>Description</u>
7825	Weatherproofed Outdoor Antenna
7825DP	Vertical Mount Dipole Antenna
7625-3dB	3dB Gain Omnidirectional Antenna
7674	6dB Gain Directional Antenna
7674-13 Yagi	13dB Gain Directional Antenna

The following accessories are available for antenna mounting:

<u>Accessory</u>	<u>Description</u>
7720 ANT	Adapter for the Remote Antenna
7670F	Remote Antenna Bracket

The following coaxial cables are available for connecting optional antennas:

<u>Cable</u>	<u>Length</u>
7626-5	Five feet long
7626-25HC	Twenty-five feet long
7626-50HC	Fifty feet long
7626-12	Twelve feet long

Always use the shortest cable that will satisfy the requirement, so as to minimize loss.

Selecting a Site (FAST Mode)

The 7820 must always be mounted indoors. If an outdoor location for the antenna or a location separate from the transmitter is required, select the proper optional antenna connection kit and follow the instructions that are enclosed. To determine the antenna location that provides optimum radio communication with the master station network, use a 7715 Micro FAST Tool or a 7915 FAST Tool.

After determining the type of installation required (UL, Non UL), find an antenna location within the premises. Locations can be found by utilizing the test mode of the 7820 on either the 7915 FAST Tool or the 7920 Series transceiver.

UL	Communication with signal strength of 3 or greater to at least two AlarmNet base stations is required for UL installations.
-----------	--

NOTES:

1. Optimum RF performance can usually be found at the highest point within a building, with the fewest number of walls between the radio and the outside of the premises.
2. Avoid mounting the antenna near other electronic devices. The following table provides minimum distances. Highest RF energy is in the direct, horizontal line of the antenna. Therefore, vertical separation (moving electronic devices either higher or lower on wall) provides a higher level of isolation from the radio.

<u>Equipment</u>	<u>Distance</u>
Short range receiver	20 ft.
PIR	10 ft.
Control panel	25 ft.
FM radio or TV ant.	25 ft.
Other devices	10 ft. minimum

 IMPORTANT	Check the appropriate box on your subscriber contract or your Request for Supervision form.
--	--

3. **Determine the mounting of the 7820 Subscriber Radio** and select suitable antenna equipment. The supplied antenna mounts directly to the 7820. The optional dipole antenna also mounts directly to the 7820 and allows the transmitter to be mounted vertically on a wall. The other antennas can mounted remotely (if desired) using pre-assembled coaxial cable available from ADEMCO (5', 12', or 25' lengths).

Figure 9 displays the 7820 mounting options and the appropriate antenna hardware to be used in each of these situations.

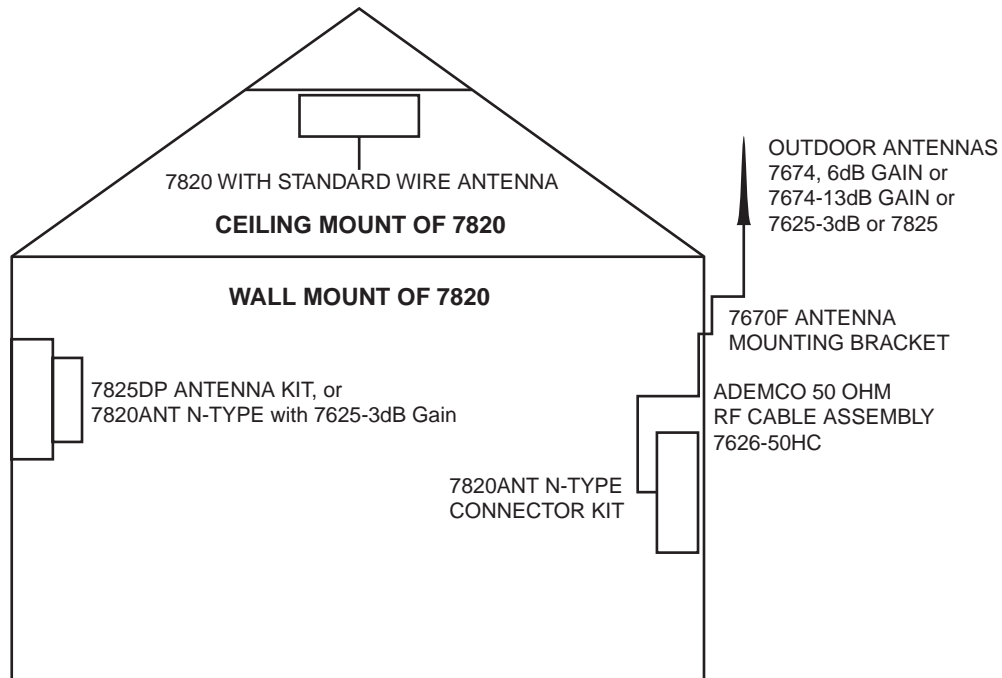



Figure 9: Ceiling and wall mount of antennas

 <p>IMPORTANT</p>	<p>The 7825 is water-resistant and is recommended for outdoor use.</p>
---	--

Outdoor Antenna Mounting

The 7820 must always be mounted indoors. If the only suitable location found is outside of the protected building, mount the 7820 close to this location on the **inside** of the building and connect an external (outdoor) antenna to the radio. Carefully follow all instructions included for these optional parts to ensure integrity of the weatherproof seals on all outside connections.

1) **Mount the 7825 Outdoor Antenna with bracket in one of the following ways (the unit must be mounted vertically):**

- **The bracket may be mounted to a wall** by using the # 10 screws and wall anchors provided. Slots "A" should be used (see Figure 10a).
- **Figure 10b shows it mounted to a pole or pipe** with two 2 1/4" U-Bolts (not provided). Slots "B" (see Figure 10a) should be used. Be sure that the pole/pipe does not extend above the base of the antenna.
- **An optional No. 7825MB Floor Mount Bracket is available** and is shown in Figure 10c. To mount the No. 7825MB Floor Mount:

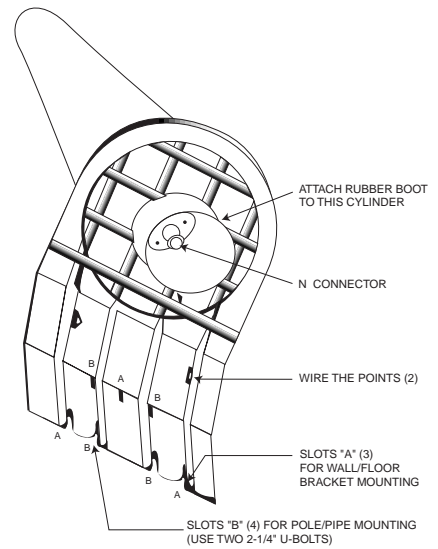

Figure 10a:
Various parts of the 7825

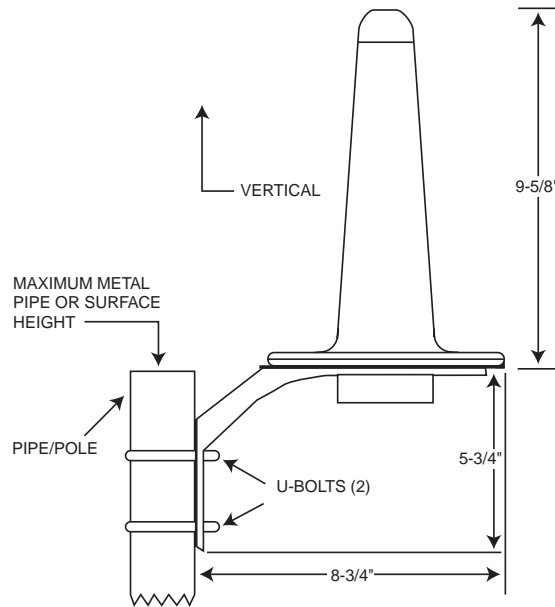

Figure 10b:
Mounting the bracket to a pole/pipe

- Secure the bracket to the floor with three screws.** Use the three 3/4" screws and anchors provided with the 7825, or other fasteners as required.
- Attach the 7825 assembly (via its slots "A") to the bracket's holes "A."** Use the three 1/2" stainless steel screws provided with the bracket.

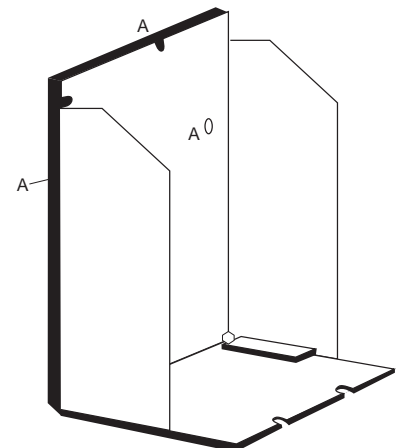

Figure 10c:
Optional No. 7825MB Floor Mount Bracket

2) **After mounting the main assembly:**

- a) **Push the N connector cable assembly through the rubber boot** in the direction shown in Figure 10d.
- b) **Connect the cable to the N connector** at the bottom of the unit.
- c) **Wire-tie the cable to a wire-tie point** so as to form a drip loop.
- d) **Push the end of the rubber boot over the 3"-diameter cylinder** at the bottom of the unit.

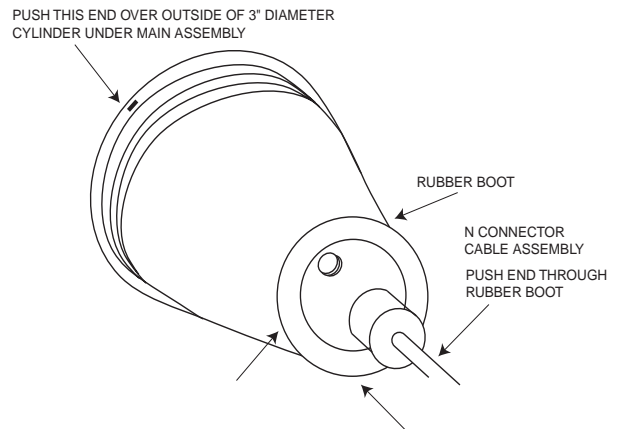

Figure 10d:
N Connector Cable assembly

Indoor Antenna Mounting

If the location found allows indoor mounting of the antenna, then the antenna selected depends on the mounting surface of the 7820. If it is possible to mount the 7820 on a ceiling or on an attic joist, you can use the included wire antenna, which provides excellent performance at no addition cost (see **Standard Wire Antenna Mounting**).

If the only mounting surface available is a wall, you can use the 7825DP (see **Wall Mounting**).

Mount the 7820 Subscriber Radio and the selected antenna kit as follows:

- **Standard Wire Antenna Mounting**
 - 1) **Mount the 7820 Subscriber Radio** on the ceiling or on an attic joist in the horizontal position.
 - 2) Replace the 7820 cover.
 - 3) Push the antenna into the antenna receptacle until it bottoms out.
 - 4) Position the antenna so it is vertical and straight.
 - 5) Rotate the antenna until it snaps into the locked position.

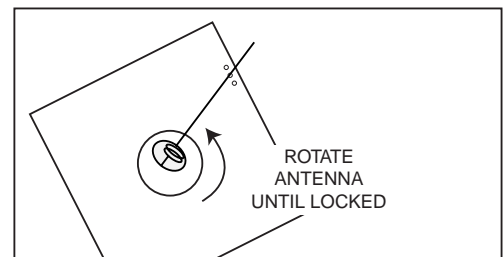

Figure 11a:
Standard wire antenna mounting

DO NOT BEND THE ANTENNA

- **Wall Mounting Using the 7825DP**

- 1) **Mount the radio to a wall** or other vertical surface. Make sure the 3 LEDs are in the upper right-hand corner.
- 2) Replace radio's cover.
- 3) Follow the enclosed Installation Instructions for installing the 7825DP to the 7820 Subscriber Radio.

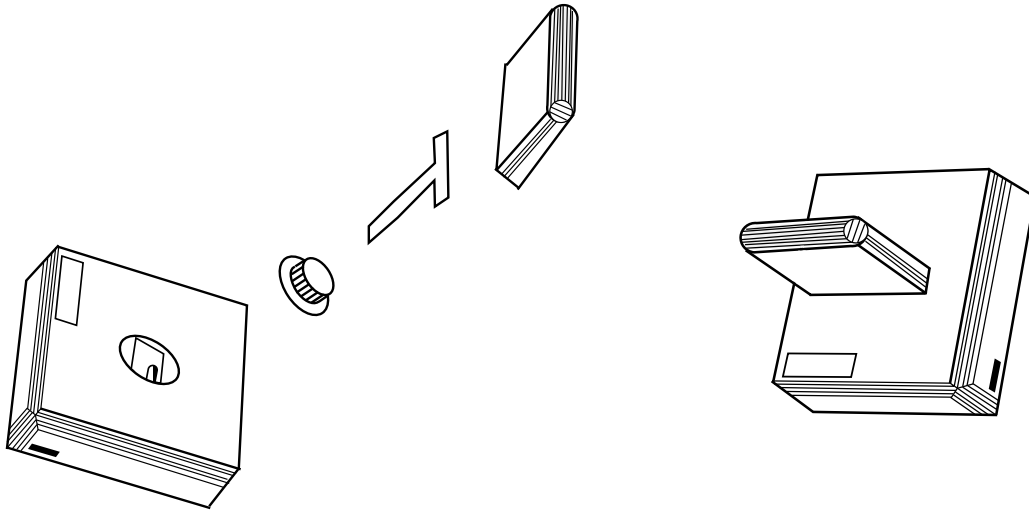

Figure 11b:
Wall mounting using the 7825DP

- **Wall Mounting with the 7625-3dB Gain and the 7720ANT Adapter**

- 1) **Mount the 7820 Subscriber Radio.**
- 2) Replace the radio's cover.
- 3) Remove the plastic insert from the cover by rotating it 45° counter-clockwise.
- 4) Replace with the insert provided with the antenna kit.
- 5) Mount the 7720ANT vertically pointing either up or down, not to the side.
- 6) Mount the 7625-3dB Gain directly on to the 7720ANT.
- 7) Mount the plastic bracket (supplied) to the wall 3 inches from the top of the antenna.

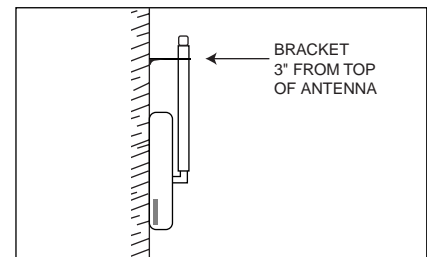
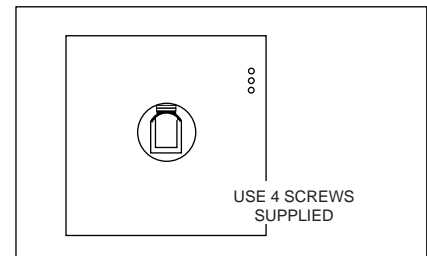
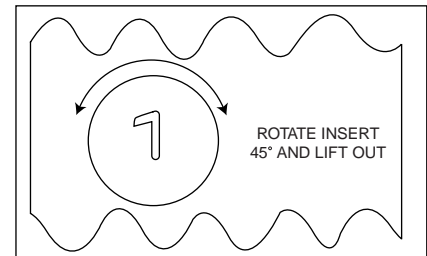

Figure 12:
**Mounting with the 7625-3dB Gain
and the 7720ANT Adapter**

- **Remote Antenna Mounting**
 - 1) **Mount the 7820 Subscriber Radio.**
 - 2) Replace the radio's cover.
 - 3) Mount the 7720ANT directly on to the 7820 radio.
 - 4) Mount antenna outdoors, following Outdoor Antenna Mounting instructions.
 - 5) Mount the ADEMCO antenna cables (see Figure 9).



IMPORTANT

1. **Use only ADEMCO Cables P/N 7626-5, 7626-12, 7626-25HC or 7626-50HC.**
2. **Do not attempt to make the antenna cables yourself, and do not under any condition try to splice them!**
3. **For detailed instructions on installing the above antenna kits, please read the enclosed Installation Instructions.**

Section 6: TESTING THE 7820

Radio Transmission Test

The 7820 is capable of sending a test message, which can be received by the central station to confirm the radio's communication link to the central station.

For AlarmNet users, the test message will cause the master station network to send a Field Triggered Diagnostic message to the central station. This message provides network information as well as signal strength and frequency characteristics of the transmitted messages. Refer to the AlarmNet User's Guide for detailed information concerning these messages. The test message can be transmitted in any of three ways.

Note: the second and third options are available only to a Zone mode radio.

1. The TEST INPUT terminals of the 7820 (located on the right side of the radio) can be shorted together, which will initiate a 90-second cycle of test message transmissions. Note that once this cycle has been initiated, it can be turned off by using the "T" command described in (2). Otherwise, the messages will not stop until the end of the cycle.
2. A 7720P Programming Tool can be used, if the radio is operating in Zone mode. To begin a cycle of test message transmissions, press SHIFT-8 ("T" command). This is a toggle function. To end the transmissions before the end of the cycle, simply enter the command again.
3. A computer terminal can be used if it is connected to the programming connector of the 7820 (only if the 7820 is in Zone mode). To begin a cycle of test message transmissions, press SHIFT-8 ("T" command) if using a 7720P; or press T if using a PC or a laptop. This is a toggle function. To end the transmissions before the end of the cycle, simply repeat the command.

System Test

Trigger an alarm by any convenient means and observe the LED indicators on the radio. The yellow LED should light solidly, followed by the green LED flashing every 1-3 seconds at first, then slowing during the 6-minute cycle. This indicates that an alarm message has been received at the radio (solid yellow), and the transmitter has been activated (green). The red LED should not light (a lit red LED would indicate a radio fault).

If the radio is configured for Zone-mode operation, and the zone is programmed for restore, restore the zone. The yellow LED should light solidly and the green LED should flash again, indicating transmission of the restore message. The central station receiver will display alarm/restore messages for each triggered alarm/restore performed.

If at any time the red LED lights, a radio fault has been detected. This could be caused by a faulty antenna connection or a failure in the RF power circuits of the radio. See Radio Fault LED on page 12. The 7720P displays diagnostic data ("S" command) related to the status of these conditions. See Status "S" Command on page 40.

Replace the cover (if removed) and perform a control panel system test.

Status "S" Command (Available only in Zone mode)

The status of the 7820 can be viewed on either a 7720P Programming Tool or an appropriate terminal when either device is connected to the serial port of the 7820. The status display includes zone input status, test terminal status, tamper status, battery condition, charging voltage status, and radio fault status. The 2-line display takes the following form:

1234TeTmBaDcFlt
5555 5 5 + + 0

1234 The numbers 1-4 represent the four zone inputs, and follow ADEMCO High Speed

Format codes:

- 1 New Event
- 2 New Opening
- 3 Restore
- 4 New Closing
- 5 Normal
- 6 Previously Reported Event
- @ Telco New Event
- P Telco Previously Reported
- p Telco Restore

Te Test terminal input codes:

- 1 Test message transmission in progress, triggered by either physical test point or "T" command.
- 5 Normal (no test message in progress).
- 6 Transmission of test message completed, but physical test point still triggered.
- P Transmission of test message pending completion of higher priority message transmission.

Tm Tamper status follows High Speed Format codes above.

Ba Represents battery condition:

- + Battery voltage acceptable
- Battery voltage below 7.4 volts and reported as bad
- X Battery not present

Dc Represents external DC input voltage:

- + DC supply voltage OK
- DC supply voltage bad (below 10.5 volts) and reported

Flt Represents radio faults. See LED flash patterns described earlier in this manual (pg. 5).

- 0 Normal
- 1 Internal radio fault*
- 5 Radio fault (bad VSWR or low RF output)*

CRC Ram/EEPROM corruption. Reset the radio and if necessary reprogram. If this fault recurs, return radio for service.

* Code 1 requires factory service. Code 5 may require factory service if troubleshooting of power supply and antenna connections does not correct problem.

Battery Status "B" Command (Available only in Zone Mode)

To check the status of the battery, or to reset its status, enter B on the 7720P Tool. The battery status will be reset, and if different from previous, will transmit the status. It will also display the status in the Ba zone of the status display.

Last Detected Fault “E” Command (Available only in Zone mode)

The last detected radio fault and the last reported radio fault can be viewed by pressing shift-5 on a 7720P Programming Tool or by pressing E on a computer terminal when either device is connected to the serial port of the 7820.

 IMPORTANT	Because the execution of this command requires access to the serial data connector, the antenna and cover must be removed. Doing so will create an RF fault as well as a tamper. To prevent this fault from overwriting a previous fault, the radio does not write the last reported fault to EEPROM if a tamper is detected.
---	--

The message is a 2-line display where the top line identifies the last fault that the 7820 detected and the second line identifies the last fault that the 7820 actually reported to the monitoring network. The **last detected fault** represents a fault that occurred on at least one transmission, but did not necessarily set the fault output. The **last reported fault** is a fault that was present for a number of transmissions (typically at least 4 consecutive transmissions) and that set the fault output. The possible fault numbers are described in the Status “S” Command paragraph above. If the detected fault does not match the reported fault value, and the transmission cycle has finished, it indicates that the fault was not present long enough for the radio to report the condition.

These values are stored in EEPROM and will be retained even when the 7820 is powered down. To erase the numbers from memory, press ESC (SHIFT-BS) as the next keystroke after pressing E. The fault value is also erased automatically upon exiting program mode.

ECP Status Codes

When the 7820 Radio is set up in ECP mode, it sends to the alarm panel the status of its battery, the tamper contact, and all of the possible failures. (See radio faults described in the Status “S” Command paragraph.)

 IMPORTANT	Note that if incoming DC voltage is lost, there can be no ECP communication with the radio.
---	--

The status is displayed upon the alarm panel remote keypad in the form of a four-digit numeric output preceded by the label “Long Rnge Fail.” The status codes are broken out as follows:

<u>Status</u>	<u>Code Explanation</u>
0000	Panel lost communication with 7820 Radio
0400	7820 Power On/Reset
0880	7820 tamper detected (cover removed from radio)
0060	7820 optional battery is low

(The following codes will never be combined; each is mutually exclusive.)

0001	7820 hardware trouble, will not transmit (PLL unlocked)
0005	Radio fault (bad VSWR or low RF output)
0006	7820 EEPROM and or RAM is corrupt (bad CRC)
0007	7820 has not been programmed

Section 7: TROUBLESHOOTING

Problem	Probable Cause	Solution
No signals received	<p>Bad antenna location</p> <p>Incorrect programming (Subscriber ID# or O/E)</p> <p>Radio fault</p>	<p>See Section 5: ANTENNA MOUNTING for antenna location and mounting.</p> <p>Verify and correct programming entry.</p> <p>If you have a 7720P, see Section 6: TESTING THE 7820.</p>
Central station does not receive alarm signals	<p>Triggering for zones/ECP not properly configured</p> <p>No ground reference</p>	<p>Verify programming for zones/ECP triggers.</p> <p>Check common ground on TB-2.</p>
<p>DC loss</p> <p>Low battery</p>	<p>Insufficient voltage/current to the 7820</p> <p>Emergency battery is below 7.5VDC</p> <p>Emergency battery not installed</p>	<p>Make sure power source is supplying 12VDC.</p> <p>Check battery voltage.</p> <p>Install battery or re-program for no battery option.</p>

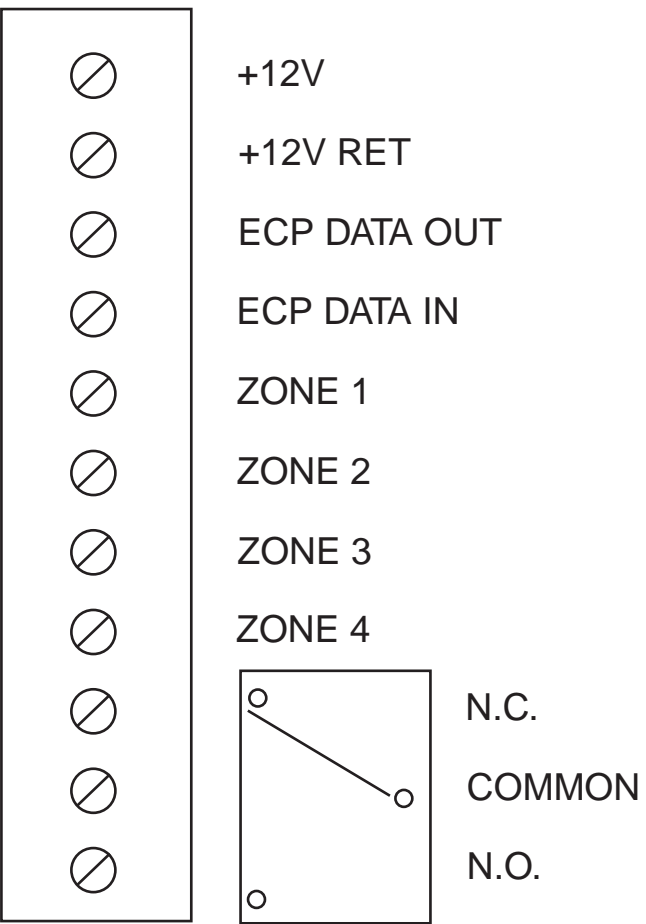

Figure 14: 7820RY Option Board connections

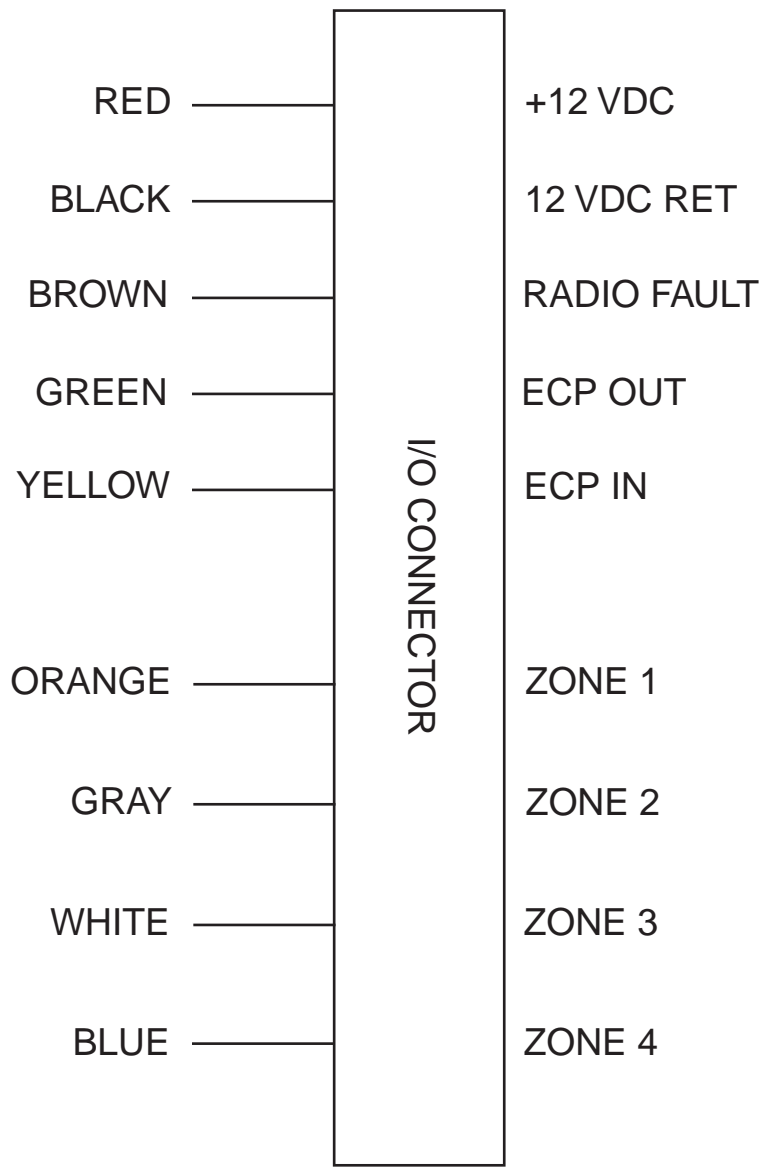

Figure 13: I/O wiring harness

Section 8: SPECIAL NOTES FOR UL INSTALLATIONS

The 7820 Subscriber Unit can be used in systems Listed by Underwriter's Laboratories for Grade A and Grade B Central Station Mercantile Burglary. The following additional requirements must be observed for the installation of subscriber remote equipment in such systems:

1. Installation must be in accordance with the National Electrical Code NFPA70, UL611, and UL681.
2. The 7820 is intended to be connected to dry contact and voltage trigger outputs of a Listed compatible control unit.
3. The 7820 must be programmed as follows:
 - a) This product is not listed for Fire Alarm Service. Therefore, zones should not be programmed as pulsed. (Programming Questions 8a, 9a, 10a, 11a.)
 - b) Delayed reporting must be programmed to 00. (Questions 8b, 9b, 10b, 11b.)
 - c) Enable restoral signals. (Questions 16, 17, 18, 19.)
 - d) The telco channel must be enabled. Do not enter 0. (Question 21.)
 - e) For zone-configured radios, a tamper zone must be enabled, and mapped to a 7820 zone. (Question 22.) (Tamper is automatically enabled in ECP-configured radios.)
 - f) Enable high-security antenna test. (Question 23.) The radio will test the antenna once every 135 seconds.
 - g) Reserved.
 - h) The Fault Out On option must be programmed Yes. (Question 25.)
 - i) The Fault Latched option must be programmed Yes. (Question 26.)
 - j) The Emergency Battery option must be installed, and Question 10 (ECP) or 24 (Zone) answered Y.
4. **FOR GRADE A CENTRAL STATION INSTALLATIONS:** A UL Listed communicator must monitor the radio fault output (terminals 10 and 11) of the 7820. A No. 659EN Telco Line Monitor's output should be connected to an input zone of the 7820 unit. (See programming Question 21.) The 659EN shall be inside the control enclosure. Premises openings and closings should be sent via the communicator. If the 7820RY option is installed, the fault relay (Questions 25 and 26) shall be programmed as Fail-Safe (fault relay ON) and wired as normally closed. In addition, the installation must meet the requirements defined for GRADE B CENTRAL STATION INSTALLATIONS below.
5. **FOR GRADE B CENTRAL STATION INSTALLATIONS:** All wiring between the 7820 and the listed control panel must be enclosed in rigid conduit (outside walls) or flexible conduit (inside walls or above ceilings). The control unit shall be a Listed Grade A Local Burglar Alarm Unit / Police Connect Unit.
6. **FOR POLICE STATION CONNECTED INSTALLATIONS:** Same requirements as for GRADE B CENTRAL STATION INSTALLATIONS defined above, except that the control panel must be Listed for GRADE A POLICE CONNECT, and premises openings and closings do not need to be sent via the communicator.
7. All wiring not run in conduit shall be contained within the same room as the 7820.

SPECIFICATIONS

Dimensions:	8.5" x 9.5" x 1.7".
Power:	12 to 15VDC, supplied from alarm panel or other DC power supply.
Current drain:	Normal standby: Above 5°C, 100 mA. Below 5° C, 225 mA, typical. With 7720P connected: unit will draw approximately 200 mA at room temperature; 325 mA max..
Fuse:	0.5A 250VDC 3AG normal blow. (ADEMCO N7577)
Fault output:	NPN device rated at 30VDC, 10mA, maximum.
Optional fault relay output:	30V, 1A.
Input triggering levels:	Zones 1 and 2: selectable GND or 4.5 to 14.2 volts into 10k-ohms. Zones 3 and 4: 4.5 to 12 volts into 10k-ohms.
RF power output:	2.5 watts nominal.
Frequency band:	928.0125 MHz to 928.3375 MHz, 25 KHz channels.
Frequency accuracy:	±5 PPM.
Operating temp:	-30 to +60 deg. Celsius.
Storage temp:	-40 to +70 deg. Celsius.
Humidity:	90% relative humidity, non-condensing.
Altitude:	To 10,000 ft. operating, to 40,000 ft storage.
Antenna:	Integral 5/8 wavelength whip. Optional case-mounted dipole. Optional type N connector permits various remote antennas.

ADDITIONAL SPECIFICATIONS RELATED TO UL INSTALLATIONS

Emergency battery:	9-volt transistor-radio battery, Duracell MN1604 or PC 1604 only.
Power supply:	If not using power from alarm panel (see page 46), then use UL-Listed supply Altronix Model AL100UL.

Section 9: APPENDICES

Unique Contact ID Messages Generated in ECP Mode

The following is a list of messages generated by the 7820 Radio when it is in ECP mode. These messages are in Contact ID format.

Message Transmitted by 7820 Radio	Message Received and Displayed on 685	Description of Alarm
3 3 3 0 0 8 X X*	R 3 3 0 C 8 X X*	Restore of Any RF Faults Reported to the Panel (Restore of System Peripheral Trouble)
1 3 3 7 0 8 X X 3 3 3 7 0 8 X X	E 3 3 7 C 8 X X R 3 3 7 C 8 X X	Line Loss (ECP DC LOSS) Restore of Line Loss (ECP DC Restore)
1 3 3 8 0 8 X X 3 3 3 8 0 8 X X	E 3 3 8 C 8 X X R 3 3 8 C 8 X X	ECP Low Battery ECP Low Battery Restore
1 3 3 9 0 8 X X	E 3 3 9 C 8 X X	ECP Power On/Reset
1 3 4 1 0 8 X X 3 3 4 1 0 8 X X	E 3 4 1 C 8 X X R 3 4 1 C 8 X X	ECP Tamper ECP Tamper Restore
1 3 5 5 0 0 0 0 3 3 5 5 0 0 0 0	E 3 5 5 C 0 0 0 R 3 5 5 C 0 0 0	Radio Lost Communication with Panel Radio Re-established Communication with Panel
* Note: "XX" = Device Address programmed into 7820 Radio. See ECP Unique Programming, Question 1. For the VIA-30P, VISTA-10, and VISTA-20, "XX" = 03 .		

ADEMCO High Speed Format

Receiver and Line Card	Customer ID Number	8 Alarm Zones	Ninth Status Bit
1 8	1 2 3 4	5 5 5 5 5 5 5 5 (Each "5" above can be a numeral from 1 to 6) 1 = Alarm 2 = Open 3 = Restore 4 = Close 5 = Normal 6 = Previously Reported	7 (A numeral from 5 through 9, and 0) *6 = System Message 7 = Alarm 9 = Test 0 = Diagnostic
* System Messages: A "6" in the ninth status bit, combined with alarm zone codes, is as follows:			
1 5 5 5 5 5 5 6	Loss of AC	(In the case of 7820, loss of radio power supply)	
5 1 5 5 5 5 5 6	Low Battery		
5 5 1 5 5 5 5 6	Poll Timeout	(Applies to two-way radios)	
5 5 5 1 5 5 5 6	Power-up/Reset		
5 5 5 5 1 5 5 6	Comm Fail		
5 5 5 5 5 1 5 6	Telco Fail		

CONTACTING TECHNICAL SUPPORT

PLEASE,

Before you call Technical Support, be sure you:

- **READ THE INSTRUCTIONS!**
- **Check all wiring connections.**
- **Determine that the power supply and/or backup battery are supplying proper voltages.**
- **Verify antenna location and environment.**
- **Verify your programming information where applicable.**
- **Note the proper model number of this product, and the software version level (if known) along with any documentation that came with the product.**
- **Note your AlarmNet Subscriber ID, Central Station Number, and Password.**

Having this information handy will make it easier for us to serve you quickly and effectively.

You may contact Technical Support via our toll-free number:

1-800-222-6525 (8 a.m. - 9 p.m. EST, Monday - Friday)

INDEX

—7—

7720P Normal & Shift Key (shift LED lit) Functions, 21

—A—

ADEMCO High Speed Format, 46
Antenna Included, 7

—B—

Battery Status “B” Command (Available only in Zone mode), 40

—C—

Choosing Mode, 21 (See ECP or Zone)
CONTACTING TECHNICAL SUPPORT, 47

—E—

ECP Status Codes, 41
ECP Unique Programming, 22
Emergency Battery, 8
Emergency Battery Operation, 11
Equipment Available, 32
Exiting Program Mode, Setting Defaults and Assigning Passwords, 30

—F—

“Fail-Safe” Relay Operation, 19

—I—

Indoor Antenna Mounting, 36
Input Power, 10
Inverted Zone Selection, 27

—L—

Last Detected Fault “E” Command (Available only in Zone mode), 41
LED Indications, 12

—M—

Mounting, 20
Mounting the Main Assembly, 36
Mounting the No. 7825MB Floor Mount Bracket, 35

—O—

Open/Close, Telco and Tamper Zone Selection, 29
Operation of the 7820 Radio, 9
Optional Adapter, 8
Outdoor Antenna Mounting, 34

—P—

Password Protection, 25
Power Connections, 15
Power Supply, 8

Powering Up, 20
Private System Users, 23, 26
Programmable Features, 7
Pulse/Delay Zone Selection, 26

—R—

Radio Fault Red LED Flash Patterns, 12
Radio Supervision, 10
Radio Transmission Test, 39
Redundant Central Station Reporting, 29
Remote Antenna Mounting, 38
Restoral Reporting Zone Selection, 28

—S—

Section 1: GENERAL DESCRIPTION, 7
Section 2: SYSTEM OPERATION, 9
Section 3: INSTALLATION AND POWER-UP PROCEDURE, 13
Section 4: PROGRAMMING THE 7820, 21
Section 5: ANTENNA MOUNTING, 32
Section 6: TESTING THE 7820, 39
Section 7: TROUBLESHOOTING, 42
Section 8: SPECIAL NOTES FOR UL INSTALLATIONS, 44
Section 9: APPENDICES, 46
Selecting a Site (FAST Mode), 32
Selection of Inputs, 7
Self-Diagnosing Transmitter, 8
Setting Factory Defaults, 31
Setting the Alarm Trigger Option (applies to Zone mode only), 13
SPECIFICATIONS, 45
Standard Wire Antenna Mounting, 36
Status “S” Command (Available only in Zone mode), 40
Subscriber Information, 25
System Test, 39

—U—

Unique Contact ID Messages Generated in ECP Mode, 46
Using a 7720P Programming Tool, 21

—W—

Wall Mounting Using the 7825DP, 37
Wall Mounting with the 7625-3dB Gain and the 7720ANT Adapter, 37
Wiring for ECP Communication, 19
Wiring for Radio Faults, 17
Wiring for Zone (Channel) Operation, 16
Wiring to the 7820 Radio, 14

—Z—

Zone (Channel) Options, 10
Zone Mode Unique Programming, 24

FEDERAL COMMUNICATIONS COMMISSION (FCC) STATEMENT

This equipment has been tested to FCC requirements and has been found acceptable for use. The FCC requires the following statement for your information:

This equipment generates and uses radio frequency energy and if not installed and used properly, that is, in strict accordance with the manufacturer's instructions, may cause interference to radio and television reception. It has been type tested and found to comply with the limits for a Class B computing device in accordance with the specifications in Part 15 of FCC Rules, which are designed to provide reasonable protection against such interference in a residential installation. However, there is no guarantee that interference will not occur in a particular installation. If this equipment does cause interference to radio or television reception, which can be determined by turning the equipment off and on, the user is encouraged to try to correct the interference by one or more of the following measures:

- If using an indoor antenna, have a quality outdoor antenna installed.
- Reorient the receiving antenna until interference is reduced or eliminated.
- Move the receiver away from the transmitter.
- Move the antenna leads away from any wire runs to the transmitter.
- Plug the transmitter into a different outlet so that it and the receiver are on different branch circuits.

If necessary, the user should consult the dealer or an experienced radio/television technician for additional suggestions.

The user or installer may find the following booklet prepared by the Federal Communications Commission helpful:

"Interference Handbook"

This booklet is available from the U.S. Government Printing Office, Washington, DC 20402. Stock No. 004-000-00450-7.

The user shall not make any changes or modifications to the equipment unless authorized by the Installation Instructions or User's Manual. Unauthorized changes or modifications could void the user's authority to operate the equipment.

TO THE INSTALLER

Regular maintenance and inspection (at least annually) by the installer and frequent testing by the user are vital to continuous satisfactory operation of any alarm system.

The installer should assume the responsibility of developing and offering a regular maintenance program to the user as well as acquainting the user with the proper operation and limitations of the alarm system and its component parts.

Recommendations must be included for a specific program of frequent testing (at least weekly) to insure the system's proper operation at all times.

THE LIMITATIONS OF THIS RADIO COMMUNICATIONS SYSTEM

While this 900 MHz Long Range Radio communications system is part of an advanced and sophisticated security system, it does not offer guaranteed protection against burglary or fire, nor does it guarantee communication of burglary or fire warning signals to a central station. Any alarm system, or any communications system, whether commercial or residential, is subject to compromise, or failure to warn, for a variety of reasons. Examples of some of these reasons are:

- Intruders may gain access through unprotected openings or have technical sophistication to bypass an alarm sensor, and then disconnect an alarm communicating radio transmitter.
- Signals sent by 900 MHz radio transmitters may be blocked by metal, mountains, hills, foliage and other natural and man made obstructions before they are received by a master receiving station or sent to a central station. Even a path previously verified as acceptable may periodically change its characteristics.
- Long-range radio communication transmitters will not work without power. Radio transmitters require a battery to work properly in the absence of AC power. A weak or dead battery, or improperly installed batteries may prevent these devices from functioning properly if AC power is disrupted for any reason.
- Radio communication systems are subject to external interference, natural or man-made, intentional or coincidental, that may keep a signal or group of signals from being successfully received by a master receiving station or a central station. In addition, one-way radio communication devices receive no acknowledgment from a master receiving station that their signals are being successfully received. Signals transmitted may clash with those transmitted from other systems. While statistical estimates predict successful operation, if the guidelines in the system manuals are followed, the operation of this system is still probabilistic in nature and may be subject to random signal failures.
- Radio communication devices may change their characteristics over time. Such parameters as frequency, modulation and power should be properly monitored periodically, with required adjustments made by qualified personnel.
- Radio communication devices must be installed by qualified personnel. Improper installation or selection of a transmitter's location may cause intermittent or unreliable performance.

Any electronic or mechanical device can fail. The most common cause of an alarm system or a radio communications system not functioning properly when an intrusion or fire occurs is inadequate maintenance, maintenance that is intended to find such failures as soon as possible. This alarm and communication system should be tested weekly to be sure all sensors and transmitters are working properly.

Installing an alarm system may make one eligible for lower insurance rates, but an alarm system is not a substitute for adequate insurance. Homeowners, property owners, business owners and renters should continue to insure their property and lives.

NOTES

ADEMCO LIMITED WARRANTY

Alarm Device Manufacturing Company, a Division of Pittway Corporation, and its divisions, subsidiaries and affiliates ("Seller"), 165 Eileen Way, Syosset, New York 11791, warrants its products to be in conformance with its own plans and specifications and to be free from defects in materials and workmanship under normal use and service for 24 months from the date stamp control on the product or, for products not having an Ademco date stamp, for 12 months from date of original purchase unless the installation instructions or catalog sets forth a shorter period, in which case the shorter period shall apply. Seller's obligation shall be limited to repairing or replacing, at its option, free of charge for materials or labor, any product which is proved not in compliance with Seller's specifications or proves defective in materials or workmanship under normal use and service. Seller shall have no obligation under this Limited Warranty or otherwise if the product is altered or improperly repaired or serviced by anyone other than Ademco factory service. For warranty service, return product transportation prepaid, to Ademco Factory Service, 165 Eileen Way, Syosset, New York 11791.

THERE ARE NO WARRANTIES, EXPRESS OR IMPLIED, OF MERCHANTABILITY, OR FITNESS FOR A PARTICULAR PURPOSE OR OTHERWISE, WHICH EXTEND BEYOND THE DESCRIPTION ON THE FACE HEREOF. IN NO CASE SHALL SELLER BE LIABLE TO ANYONE FOR ANY CONSEQUENTIAL OR INCIDENTAL DAMAGES FOR BREACH OF THIS OR ANY OTHER WARRANTY, EXPRESS OR IMPLIED, OR UPON ANY OTHER BASIS OF LIABILITY WHATSOEVER, EVEN IF THE LOSS OR DAMAGE IS CAUSED BY THE SELLER'S OWN NEGLIGENCE OR FAULT.

Seller does not represent that the products it sells may not be compromised or circumvented; that the products will prevent any personal injury or property loss by burglary, robbery, fire or otherwise; or that the products will in all cases provide adequate warning or protection. Customer understands that a properly installed and maintained alarm may only reduce the risk of a burglary, robbery, fire or other events occurring without providing an alarm, but it is not insurance or a guarantee that such will not occur or that there will be no personal injury or property loss as a result. CONSEQUENTLY, SELLER SHALL HAVE NO LIABILITY FOR ANY PERSONAL INJURY, PROPERTY DAMAGE OR OTHER LOSS BASED ON A CLAIM THE PRODUCT FAILED TO GIVE WARNING. HOWEVER, IF SELLER IS HELD LIABLE, WHETHER DIRECTLY OR INDIRECTLY, FOR ANY LOSS OR DAMAGE ARISING UNDER THIS LIMITED WARRANTY OR OTHERWISE, REGARDLESS OF CAUSE OR ORIGIN, SELLER'S MAXIMUM LIABILITY SHALL NOT IN ANY CASE EXCEED THE PURCHASE PRICE OF THE PRODUCT, WHICH SHALL BE THE COMPLETE AND EXCLUSIVE REMEDY AGAINST SELLER. This warranty replaces any previous warranties and is the only warranty made by Seller on this product. No increase or alteration, written or verbal, of the obligations of this Limited Warranty is authorized.

ADEMCO
GROUP

165 Eileen Way, Syosset, NY 11791

Copyright © 1996 PITTWAY CORPORATION



N7705V1 Rev.B 8/98